

Three-Phase Transformer Banks

FESTO

Electricity and New Energy

LabVolt Series

Student Manual



FESTO

Student Manual

Three-Phase Transformer Banks

Germany

Festo Didactic SE
Rechbergstr. 3
73770 Denkendorf
Tel.: +49 711 3467-0
Fax: +49 711 347-54-88500
did@festo.com

United States

Festo Didactic Inc.
607 Industrial Way West
Eatontown, NJ 07724
Tel.: +1 732 938-2000
Toll Free: +1-800-522-8658
Fax: +1 732 774-8573
services.didactic@festo.com

Canada

Festo Didactic Ltée/Ltd
675, rue du Carbone
Québec (Québec) G2N 2K7
Tel.: +1 418 849-1000
Toll Free: +1-800-522-8658
Fax: +1 418 849-1666
services.didactic@festo.com

www.festo-didactic.com



000057944800000000000100

Festo Didactic
en
579448

Electricity and New Energy

Three-Phase Transformer Banks

Student Manual

579448

Order no.: 579448
First Edition
Revision level: 09/2016

By the staff of Festo Didactic

© Festo Didactic Ltée/Ltd, Quebec, Canada 2011
Internet: www.festo-didactic.com
e-mail: did@de.festo.com

Printed in Canada
All rights reserved
ISBN 978-2-89640-514-5 (Printed version)
ISBN 978-2-89640-747-7 (CD-ROM)
Legal Deposit – Bibliothèque et Archives nationales du Québec, 2011
Legal Deposit – Library and Archives Canada, 2011

The purchaser shall receive a single right of use which is non-exclusive, non-time-limited and limited geographically to use at the purchaser's site/location as follows.

The purchaser shall be entitled to use the work to train his/her staff at the purchaser's site/location and shall also be entitled to use parts of the copyright material as the basis for the production of his/her own training documentation for the training of his/her staff at the purchaser's site/location with acknowledgement of source and to make copies for this purpose. In the case of schools/technical colleges, training centers, and universities, the right of use shall also include use by school and college students and trainees at the purchaser's site/location for teaching purposes.

The right of use shall in all cases exclude the right to publish the copyright material or to make this available for use on intranet, Internet and LMS platforms and databases such as Moodle, which allow access by a wide variety of users, including those outside of the purchaser's site/location.

Entitlement to other rights relating to reproductions, copies, adaptations, translations, microfilming and transfer to and storage and processing in electronic systems, no matter whether in whole or in part, shall require the prior consent of Festo Didactic.

















Information in this document is subject to change without notice and does not represent a commitment on the part of Festo Didactic. The Festo materials described in this document are furnished under a license agreement or a nondisclosure agreement.

Festo Didactic recognizes product names as trademarks or registered trademarks of their respective holders.

All other trademarks are the property of their respective owners. Other trademarks and trade names may be used in this document to refer to either the entity claiming the marks and names or their products. Festo Didactic disclaims any proprietary interest in trademarks and trade names other than its own.

Safety and Common Symbols

The following safety and common symbols may be used in this manual and on the equipment:

Symbol	Description
	DANGER indicates a hazard with a high level of risk which, if not avoided, will result in death or serious injury.
	WARNING indicates a hazard with a medium level of risk which, if not avoided, could result in death or serious injury.
	CAUTION indicates a hazard with a low level of risk which, if not avoided, could result in minor or moderate injury.
	CAUTION used without the <i>Caution, risk of danger</i> sign  , indicates a hazard with a potentially hazardous situation which, if not avoided, may result in property damage.
	Caution, risk of electric shock
	Caution, hot surface
	Caution, risk of danger
	Caution, lifting hazard
	Caution, hand entanglement hazard
	Notice, non-ionizing radiation
	Direct current
	Alternating current
	Both direct and alternating current
	Three-phase alternating current
	Earth (ground) terminal

Safety and Common Symbols









Symbol	Description
	Protective conductor terminal
	Frame or chassis terminal
	Equipotentiality
	On (supply)
	Off (supply)
	Equipment protected throughout by double insulation or reinforced insulation
	In position of a bi-stable push control
	Out position of a bi-stable push control

Table of Contents

Preface	VII
About This Manual	IX
Introduction Three-Phase Transformer Banks	1
DISCUSSION OF FUNDAMENTALS	1
Introduction to three-phase power transformers	1
Types of three-phase power transformers	2
Connecting the windings of three-phase transformer banks in wye and in delta	2
Wye-connected secondary windings.....	3
Delta-connected secondary windings.....	4
Exercise 1 Three-Phase Transformer Configurations.....	5
DISCUSSION.....	5
Common three-phase transformer configurations.....	5
Voltage, current, and phase relationships of the four common three-phase transformer configurations.....	7
Wye-wye and delta-delta configurations	7
Wye-delta configuration	7
Delta-wye configuration.....	7
Summary of the characteristics of the four common three-phase transformer configurations	8
Uses of three-phase transformer banks	9
PROCEDURE	10
Set up and connections	10
Voltage, current, and phase relationships in a wye-wye configuration	12
Voltage, current, and phase relationships in a wye-delta configuration	14
Voltage, current, and phase relationships in a delta-delta configuration	16
Voltage, current, and phase relationships in a delta-wye configuration	19
Appendix A Equipment Utilization Chart.....	27
Appendix B Glossary of New Terms	29
Appendix C Impedance Table for the Load Modules	31
Appendix D Circuit Diagram Symbols	33
Index of New Terms.....	39

Table of Contents

Bibliography	41
--------------------	----

Preface

The production of energy using renewable natural resources such as wind, sunlight, rain, tides, geothermal heat, etc., has gained much importance in recent years as it is an effective means of reducing greenhouse gas (GHG) emissions. The need for innovative technologies to make the grid smarter has recently emerged as a major trend, as the increase in electrical power demand observed worldwide makes it harder for the actual grid in many countries to keep up with demand. Furthermore, electric vehicles (from bicycles to cars) are developed and marketed with more and more success in many countries all over the world.

To answer the increasingly diversified needs for training in the wide field of electrical energy, the Electric Power Technology Training Program was developed as a modular study program for technical institutes, colleges, and universities. The program is shown below as a flow chart, with each box in the flow chart representing a course.

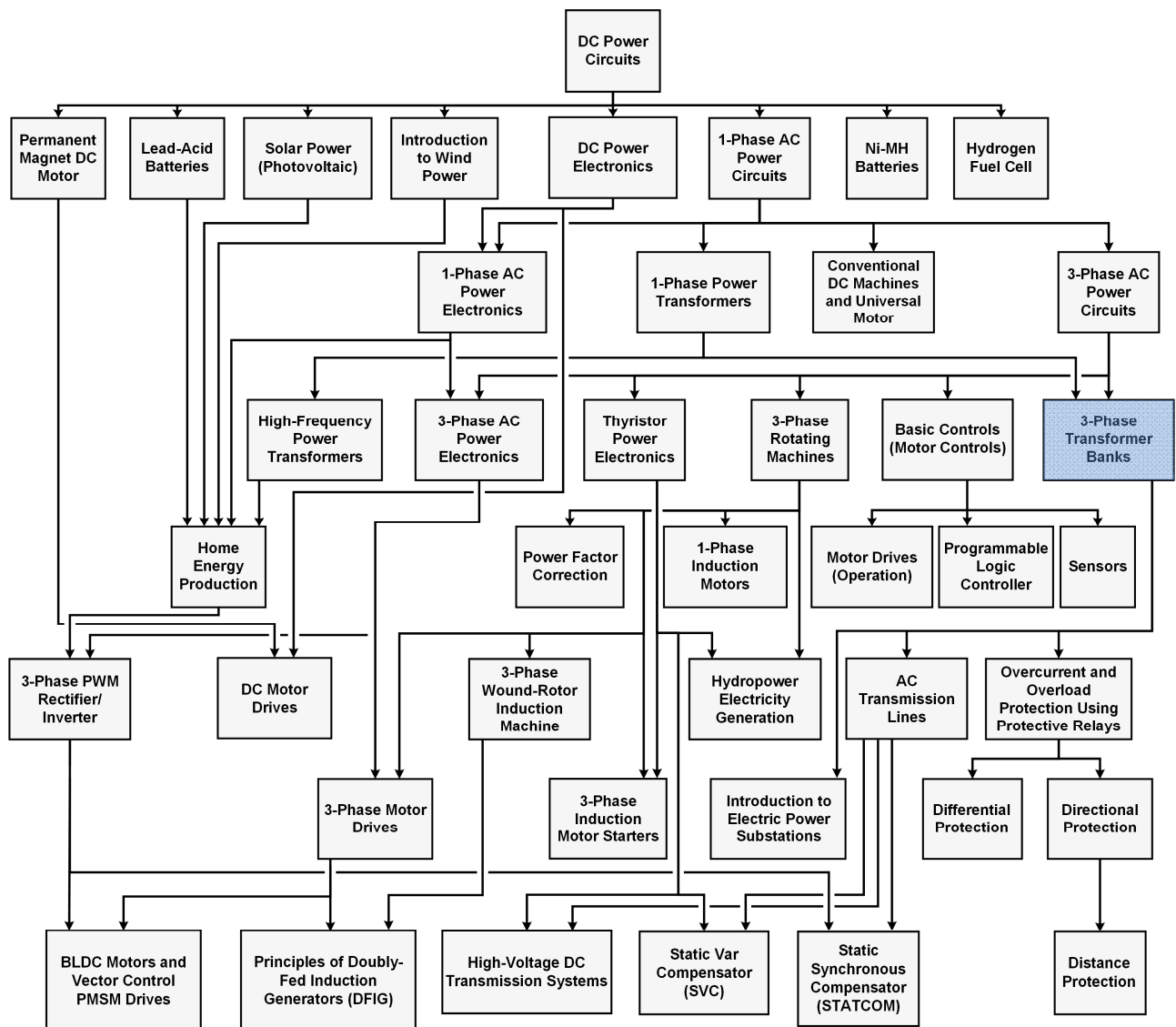

The Electric Power Technology Training Program.

Preface

The program starts with a variety of courses providing in-depth coverage of basic topics related to the field of electrical energy such as ac and dc power circuits, power transformers, rotating machines, ac power transmission lines, and power electronics. The program then builds on the knowledge gained by the student through these basic courses to provide training in more advanced subjects such as home energy production from renewable resources (wind and sunlight), large-scale electricity production from hydropower, large-scale electricity production from wind power (doubly-fed induction generator [DFIG], synchronous generator, and asynchronous generator technologies), smart-grid technologies (SVC, STATCOM, HVDC transmission, etc.), storage of electrical energy in batteries, and drive systems for small electric vehicles and cars.

We invite readers of this manual to send us their tips, feedback, and suggestions for improving the book.

Please send these to did@de.festo.com.

The authors and Festo Didactic look forward to your comments.

About This Manual

Three-phase transformer banks serve the same purpose in three-phase circuits as single-phase power transformers in single-phase circuits. This means that three-phase transformer banks are primarily used to either step-up (i.e., to increase) the voltage from the primary windings to the secondary windings, or to step-down (i.e., to decrease) the voltage from the primary windings to the secondary windings. Since three-phase ac power is widely used worldwide for both power transmission and power distribution, three-phase transformer banks are one of the most common electrical components and are essential to any three-phase ac power network.

Many three-phase transformer configurations are possible when connecting the primary and secondary windings of a three-phase transformer bank. Each configuration presents different characteristics. When connecting a three-phase transformer bank in a circuit, it is therefore important to determine which characteristics are advantageous to the circuit, and to choose the three-phase transformer configuration accordingly. The four most common three-phase transformer configurations are the wye-wye, delta-delta, wye-delta, and delta-wye configurations.

This manual, *Three-Phase Transformer Banks*, teaches the basic concepts of three-phase transformer banks. Students are introduced to the different characteristics of three-phase transformer banks. They learn how to connect the windings of three-phase transformer banks in wye or delta. Students are also introduced to the four most common types of three-phase transformer configurations: wye-wye, delta-delta, wye-delta, and delta-wye. Students determine the voltage, current, and phase relationships between the primary windings and the secondary windings of three-phase transformer banks for each of these configurations. They learn how to ensure proper phase relationships between the phase windings. Students also verify the theory presented in the manual by performing circuit measurements and calculations.



Three-phase transformer bank used for power distribution.

About This Manual

Safety considerations

Safety symbols that may be used in this manual and on the equipment are listed in the Safety Symbols table at the beginning of the manual.

Safety procedures related to the tasks that you will be asked to perform are indicated in each exercise.

Make sure that you are wearing appropriate protective equipment when performing the tasks. You should never perform a task if you have any reason to think that a manipulation could be dangerous for you or your teammates.

Prerequisite

As a prerequisite to this course, you should have read the manuals titled *DC Power Circuits*, *Single-Phase AC Power Circuits*, *Single-Phase Power Transformers*, and *Three-Phase AC Power Circuits*.

Systems of units

Units are expressed using the International System of Units (SI) followed by units expressed in the U.S. customary system of units (between parentheses).

Three-Phase Transformer Banks

MANUAL OBJECTIVE

When you have completed this manual, you will be familiar with the operation of three-phase transformer banks. You will know how to connect the windings of a three-phase transformer bank in wye or delta. You will also know how to connect a three-phase transformer bank in a wye-wye, delta-delta, wye-delta, or delta-wye configuration. You will be introduced to the voltage, current, and phase relationships between the primary windings and the secondary windings for each of these configurations. Finally, you will be familiar with the different uses of three-phase transformer banks in three-phase ac power circuits.

DISCUSSION OUTLINE

The Discussion of Fundamentals covers the following points:

- Introduction to three-phase power transformers
- Types of three-phase power transformers
- Connecting the windings of three-phase transformer banks in wye and in delta

DISCUSSION OF FUNDAMENTALS

Introduction to three-phase power transformers

Three-phase power transformers serve the same purpose in three-phase circuits as single-phase power transformers in single-phase circuits. This means that three-phase power transformers are primarily used to either step-up (i.e., to increase) the voltage from the primary windings to the secondary windings, or to step-down (i.e., to decrease) the voltage from the primary windings to the secondary windings. Three-phase power transformers achieve this through the same means as single-phase power transformers, i.e., through electromagnetic induction between the primary windings and the secondary windings. Three-phase power transformers, just as single-phase power transformers, are bidirectional devices and provide isolation from the primary windings to the secondary windings.

The voltage and current ratios of three-phase power transformers depend on the turns ratio (i.e., on the ratio of the number of turns of wire at the primary to the number of turns of wire at the secondary), just as for single-phase power transformers. When the number of turns at the primary of a three-phase power transformer is less than the number of turns at the secondary, it acts as a step-up transformer. Conversely, when the number of turns at the primary of a three-phase power transformer is greater than the number of turns at the secondary, it acts as a step-down transformer.

Each winding (either at the primary or at the secondary) of a three-phase power transformer has a particular polarity at any given instant, in relation to the polarity of the other windings, just as for single-phase power transformers. The polarity of any winding of a three-phase power transformer can be determined in the same way as for single-phase power transformers. The polarity of any winding of a

three-phase power transformer is very important when connecting the winding to other windings.

The power rating of a three-phase power transformer is equal to the sum of the power ratings of the primary windings (this sum is equal to the sum of the power ratings of the secondary windings), just as for single-phase power transformers. The power losses (i.e., the copper and iron losses) occurring in a three-phase power transformer are very similar to those occurring in single-phase power transformers. The efficiency of the three-phase power transformer is affected by the power losses in the same way as for single-phase power transformers. Three-phase power transformers, as any power transformer, are very efficient devices.

The saturation occurring in three-phase power transformers is affected in the same way as for single-phase power transformers. Thus, the higher the operating frequency of the three-phase power transformer, the less it is saturated. Also, the voltage, current, and power ratings of three-phase power transformers are determined so that the saturation occurring in the three-phase power transformer is maintained at an acceptable level, just as for single-phase power transformers. This means that, the higher the operating frequency of the three-phase power transformer, the higher the voltage, current, and power ratings of the three-phase power transformer can be for a given level of saturation.

Types of three-phase power transformers

There are two basic types of three-phase power transformers: **single-unit, three-phase power transformers** and **three-phase transformer banks**. Single-unit, three-phase power transformers are constructed by winding three single-phase power transformers around a single core. On the other hand, three-phase transformer banks consist of three individual single-phase power transformers that are grouped together. For a given power rating, single-unit, three-phase power transformers are smaller, require less material, and are less costly than three-phase transformer banks. Three-phase transformer banks, however, are easier to maintain than single-unit, three-phase power transformers because, when one of the windings is defective, the corresponding defective transformer in the bank can be individually replaced instead of having to replace the whole unit.

Note that, since this manual covers three-phase transformer banks, three-phase power transformers will now be referred to exclusively as three-phase transformer banks. However, the basic operating principles of single-unit, three-phase power transformers are the same as those of three-phase transformer banks. The theory presented in the remainder of this manual is thus valid for both types of three-phase power transformers.

Connecting the windings of three-phase transformer banks in wye and in delta

When connecting the primary windings or the secondary windings of three-phase transformer banks, the phase sequence should always be respected for the phase relationship between the primary and secondary voltages to be as expected. For instance, when the primary winding of one of the transformers in a

three-phase transformer bank is connected to phase 1 of the ac power source, the secondary winding of this transformer should be considered phase 1 of the system. Also, when connecting the primary windings or the secondary windings of the transformers used in a three-phase transformer bank, the polarity of the windings should always be respected. This ensures that the phase relationship of the voltages across the secondary windings is as expected.

Because any error in the connections of the primary windings or the secondary windings of three-phase transformer banks is likely to change the phase relationship of the various voltages at the secondary windings, some extra precautions must be taken before the three-phase transformer bank can be put into service. This is discussed in the following subsections of this introduction.

Wye-connected secondary windings

To set up the secondary windings of a three-phase transformer bank in wye, it is necessary to connect the three windings together at a common point for interconnection with the neutral wire and then, to connect the other end of each winding to the three line wires. Once this is done, the phase relationship of the voltages at the secondary windings can be verified by confirming that all line voltages at the secondary are $\sqrt{3}$ times greater than the phase voltages. This can be achieved using the following procedure:

1. Measure the line voltage between any two windings (e.g., line voltage E_{A-B}) to confirm that it is $\sqrt{3}$ times greater than the phase voltage across either of the two windings (e.g., phase voltage E_{A-N}). This is shown in Figure 1a.
2. Measure the line voltages between the third winding and the other windings (e.g., line voltages E_{C-A} and E_{B-C}) to confirm that both are $\sqrt{3}$ times greater than the phase voltage measured in the first step (e.g., phase voltage E_{A-N}). This is shown in Figure 1b.

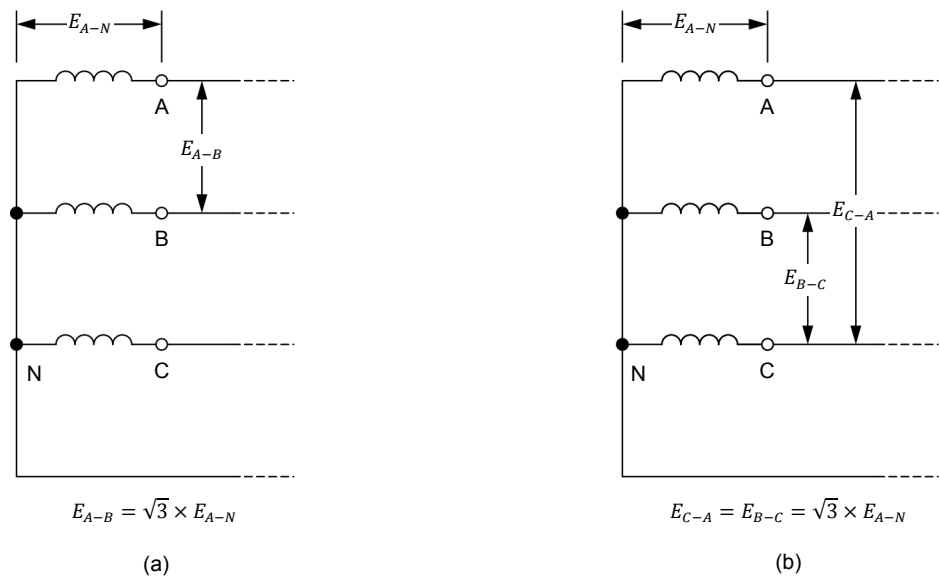

Figure 1. Connecting the secondary windings of a three-phase transformer bank in wye.

Delta-connected secondary windings

To set up the secondary windings of a three-phase transformer bank in delta, it is necessary to connect the first winding in series with the second, the second in series with the third, and the third in series with the first to close the delta loop. The three line wires are then separately connected to each junction in the delta loop. However, when connecting the secondary windings of a three-phase transformer bank in a delta configuration, it is important to verify that the phase relationship of the voltages at the secondary windings are correct before closing the delta loop. This is due to the fact that, if the polarity of the windings of the three-phase transformer bank are not respected, a very high short-circuit current will flow in the secondary windings. This could seriously damage the three-phase transformer bank. It is therefore necessary to use the following procedure when connecting the secondary windings of a three-phase transformer bank in delta:

1. Measure the voltage across two series-connected windings (e.g., voltage E_{C-A}) to confirm that it is equal to the voltage across either of the two windings (e.g., voltages E_{A-B} and E_{B-C}). This is shown in Figure 2a.
2. Connect the third winding in series.
3. Measure the voltage across the three series-connected windings (e.g., voltage E_{C-D}) to confirm that it is equal to zero. This is shown in Figure 2b.
4. Once you have confirmed that the polarity of the secondary windings of the three-phase transformer bank is respected (i.e., once you have completed steps 1 to 3 of this procedure), close the delta.

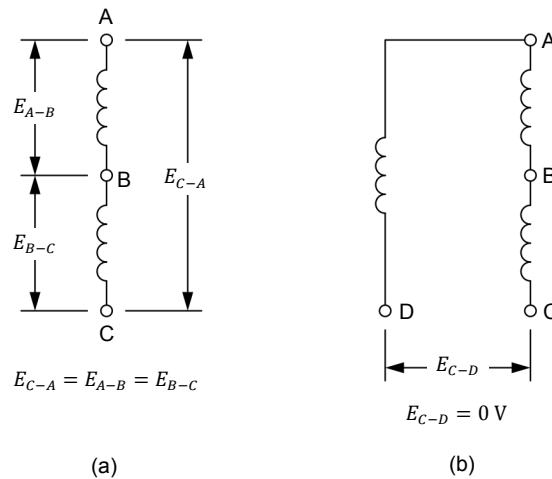

Figure 2. Connecting the secondary windings of a three-phase transformer bank in delta.

Three-Phase Transformer Configurations

EXERCISE OBJECTIVE

When you have completed this exercise, you will know how to connect three-phase transformer banks in wye-wye, delta-delta, wye-delta, and delta-wye configurations. You will determine the voltage, current, and phase relationships between the primary windings and the secondary windings of a three-phase transformer bank for each of these configurations. You will be familiar with the different uses of three-phase transformer banks in three-phase ac power circuits.

DISCUSSION OUTLINE

The Discussion of this exercise covers the following points:

- Common three-phase transformer configurations
- Voltage, current, and phase relationships of the four common three-phase transformer configurations
- Summary of the characteristics of the four common three-phase transformer configurations
- Uses of three-phase transformer banks

DISCUSSION

Common three-phase transformer configurations

Many **three-phase transformer configurations** are possible when connecting the primary and secondary windings of a three-phase transformer bank. Each configuration presents different characteristics. When connecting a three-phase transformer bank in a circuit, it is therefore important to determine which characteristics are advantageous to the circuit, and to choose the appropriate three-phase transformer configuration accordingly.

The four most common three-phase transformer configurations are wye-wye, delta-delta, wye-delta, and delta-wye configurations. Each of these configurations is shown in Figure 3. The letter (A, B, or C) beside each winding in Figure 3 identifies one of the transformers in a three-phase transformer bank. This allows the primary and secondary windings of each transformer in the three-phase transformer bank to be easily located in the diagrams of Figure 3.

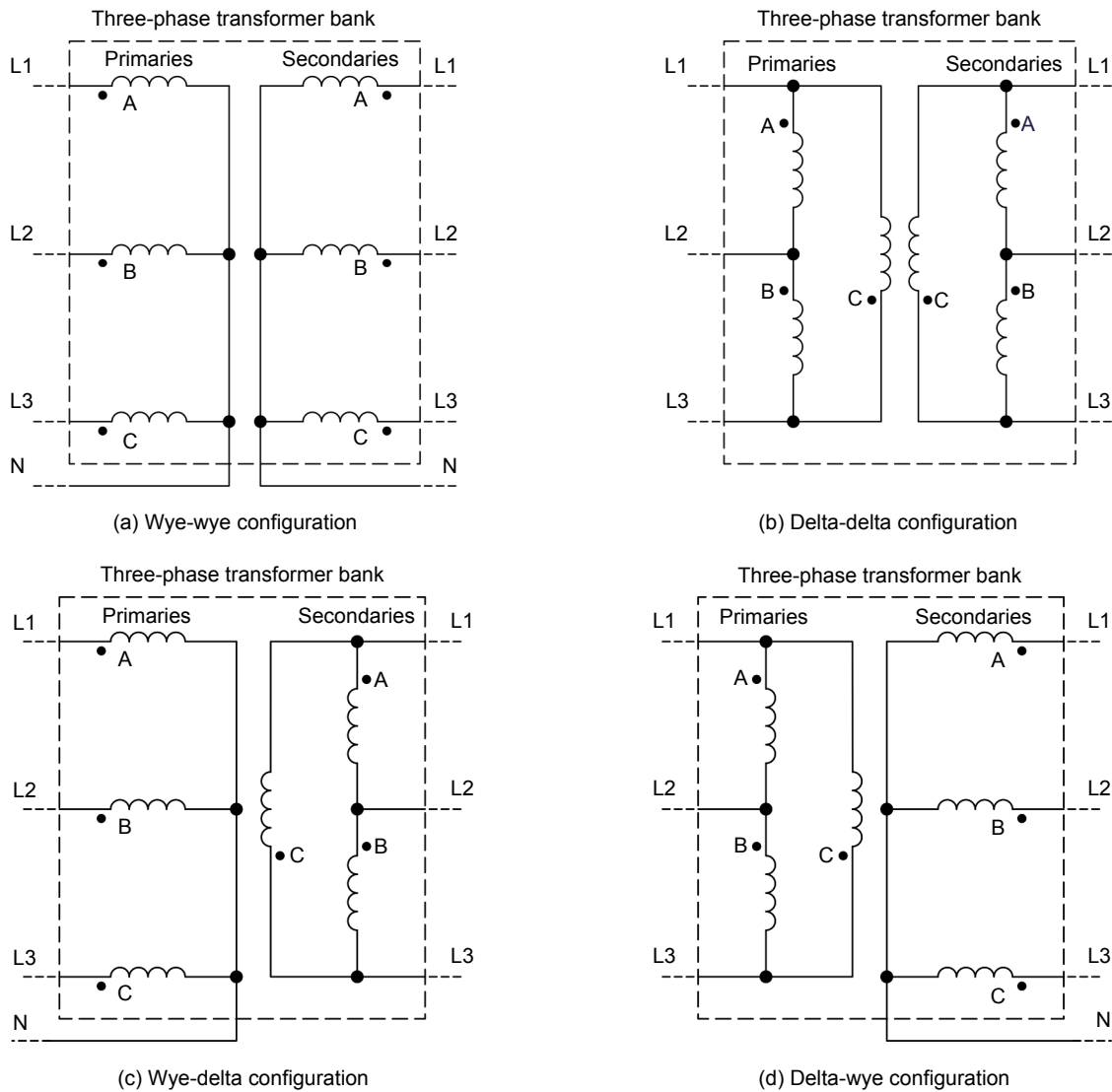

Figure 3. The four most common three-phase transformer configurations.

As you can see from the figure, wye-connected windings use 4 wires, while delta-connected windings use only 3 wires. When setting up a three-phase transformer bank in a wye-delta or delta-wye configuration, this property allows the number of wires in a three-phase ac circuit to be modified from 4 wires to 3 wires, or from 3 wires to 4 wires, respectively. Either of these configurations can be a significant advantage, depending on the requirements of the particular application in which it is used.

Voltage, current, and phase relationships of the four common three-phase transformer configurations

The most determining characteristics of each three-phase transformer configuration mentioned in the previous section (i.e., the wye-wye, delta-delta, wye-delta, and delta-wye configurations) are their respective voltage, current, and phase relationships between the primary windings and the secondary windings. The following three sections discuss these relationships for each three-phase transformer configuration. Note that, as wye-wye and delta-delta configurations have similar voltage, current, and phase relationships, both configurations are covered in the same section. Also note that, in the following sections, the turns ratio of each transformer in the three-phase transformer bank is assumed to be equal to 1:1. This allows observation of the effects each configuration has on the voltage, current, and phase relationships of the three-phase transformer bank, independently of the turns ratio.

Wye-wye and delta-delta configurations

When a three-phase transformer bank is connected in either a wye-wye or a delta-delta configuration, the voltage, current, and phase relationships between the primary windings and the secondary windings are identical to the relationships found in a conventional single-phase power transformer. This means that the values of the line voltages and currents at the secondary are equal to those of the line voltages and currents at the primary (neglecting transformer losses). Also, the line voltage sine waves at the secondary are in phase with the line voltage sine waves at the primary. The same is true for the line current sine waves at the secondary with respect to the line current sine waves at the primary.

Wye-delta configuration

When a three-phase transformer bank is connected in a wye-delta configuration, the values and phases of the line voltages and currents at the secondary are different from those at the primary. Thus, in a wye-delta configuration, the value of the line voltages at the secondary is equal to that of the line voltages at the primary divided by $\sqrt{3}$. Conversely, the value of the line currents at the secondary is equal to that of the line currents at the primary multiplied by $\sqrt{3}$. Furthermore, the line voltage sine waves at the secondary lag behind those at the primary by 30° . The same is true for the line current sine waves at the secondary with respect to the line current sine waves at the primary.

Delta-wye configuration

When a three-phase transformer bank is connected in a delta-wye configuration, the values and phases of the line voltages and currents at the secondary are different from those at the primary. Thus, in a delta-wye configuration, the value of the line voltages at the secondary is equal to that of the line voltages at the primary multiplied by $\sqrt{3}$. Conversely, the value of the line currents at the secondary is equal to that of the line currents at the primary divided by $\sqrt{3}$. Furthermore, the line voltage sine waves at the secondary lead those at the primary by 30° . The same is true for the line current sine waves at the secondary with respect to the line current sine waves at the primary.

Summary of the characteristics of the four common three-phase transformer configurations

The following table gives a summary of the different characteristics of the four three-phase transformer configurations presented in the previous section (i.e., the wye-wye, delta-delta, wye-delta, and delta-wye configurations).

Table 1. Summary of the characteristics of three-phase transformer configurations.

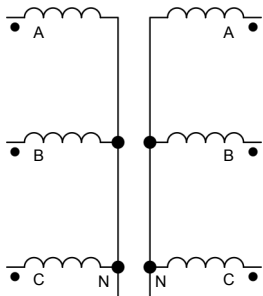
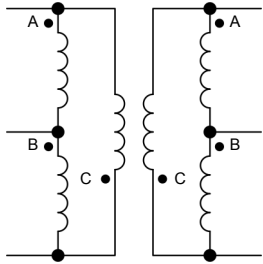
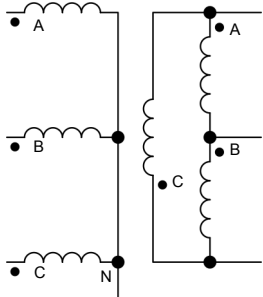
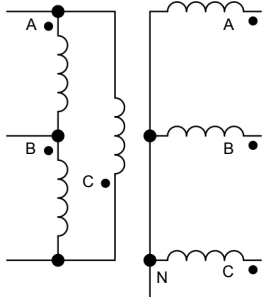
Three-phase transformer configuration	Line voltage relationship ($E_{Pri.}:E_{Sec.}$)	Line current relationship ($I_{Pri.}:I_{Sec.}$)	Phase shift (Sec. with respect to Pri.)	Number of wires (Pri.:Sec.)
 <p>Wye-wye configuration</p>	1:1	1:1	0°	4:4
 <p>Delta-delta configuration</p>	1:1	1:1	0°	3:3
 <p>Wye-delta configuration</p>	$\sqrt{3}:1$	$1:\sqrt{3}$	-30° (30° lag)	4:3
 <p>Delta-wye configuration</p>	$1:\sqrt{3}$	$\sqrt{3}:1$	30° (30° lead)	3:4

Remember that the line voltage and current relationships presented in Table 1 are valid only when the turns ratio of the transformers in the three-phase transformer bank is equal to 1:1. When the turns ratio of the transformers in the three-phase transformer bank is not 1:1, the actual line voltages at the secondary can be found by multiplying the primary line voltages by the voltage ratio appropriate to the configuration of the three-phase transformer bank and the inverse of the turns ratio ($N_{Sec.}/N_{Pri.}$) of the transformers. Similarly, the actual line currents at the secondary can be found by multiplying the primary line currents by the current ratio appropriate to the configuration of the three-phase transformer bank and the turns ratio ($N_{Pri.}/N_{Sec.}$) of the transformers.

Uses of three-phase transformer banks

Three-phase transformer banks are used in three-phase ac power circuits for basically the same reasons as single-phase power transformers in single-phase ac circuits, i.e., to step-up or step-down the voltages in the circuit and to provide electrical isolation between the primary windings and the secondary windings. However, the special properties of certain three-phase transformer configurations presented in the previous sections allow three-phase transformer banks to be used in a few additional applications. The primary uses of three-phase transformer banks in three-phase ac power circuits are summarized below.

1. Three-phase transformer banks allow the voltages in the three-phase ac power circuit to be stepped-up (i.e., to be increased) or stepped-down (i.e., to be decreased).
2. Three-phase transformer banks provide electrical isolation between the primary windings and the secondary windings.
3. Three-phase transformer banks connected in a wye-delta or in a delta-wye configuration allow the number of wires in the three-phase ac power circuit to be decreased from 4 to 3, or increased from 3 to 4, respectively.
4. Three-phase transformer banks connected in a wye-delta or in a delta-wye configuration allow the incoming line voltages and currents to be phase shifted -30° or 30° , respectively.

PROCEDURE OUTLINE

The Procedure is divided into the following sections:

- Set up and connections
- Voltage, current, and phase relationships in a wye-wye configuration
- Voltage, current, and phase relationships in a wye-delta configuration
- Voltage, current, and phase relationships in a delta-delta configuration
- Voltage, current, and phase relationships in a delta-wye configuration

PROCEDURE



High voltages are present in this laboratory exercise. Do not make or modify any banana jack connections with the power on unless otherwise specified.

Set up and connections

In this section, you will set up a circuit containing a three-phase transformer bank connected in a wye-wye configuration. You will then set the measuring equipment required to study the voltage, current, and phase relationships of the three-phase transformer bank.

1. Refer to the Equipment Utilization Chart in Appendix A to obtain the list of equipment required to perform this exercise.

Install the required equipment in the [Workstation](#).

2. Make sure that the ac and dc power switches on the [Power Supply](#) module are set to the **O** (off) position, then connect the [Power Supply](#) module to a three-phase ac power outlet.

Connect the [Power Input](#) of the [Data Acquisition and Control Interface](#) module to the [24 V AC Power Supply](#) module. Turn the [24 V AC Power Supply](#) module on.

3. Connect the [USB](#) port of the [Data Acquisition and Control Interface](#) module to a USB port of the host computer.

4. Turn the host computer on, then start the [LVDAC-EMS](#) software.

In the [LVDAC-EMS Start-Up](#) window, make sure that the [Data Acquisition and Control Interface](#) is detected. Make sure that the [Computer-Based Instrumentation](#) function for the [Data Acquisition and Control Interface](#) is available. Select the network voltage and frequency that correspond to the voltage and frequency of your local ac power network, then click the [OK](#) button to close the [LVDAC-EMS Start-Up](#) window.

5. Connect the equipment as shown in Figure 4.



The values of the resistive loads used in the circuits of this manual depend on your local ac power network voltage and frequency. Whenever necessary, a table below the circuit diagram indicates the resistance of each load resistor for ac power network voltages of 120 V, 220 V, 230 V and 240 V, and for ac power network frequencies of 50 Hz and 60 Hz. Make sure to use the component values corresponding to your local ac power network voltage and frequency.

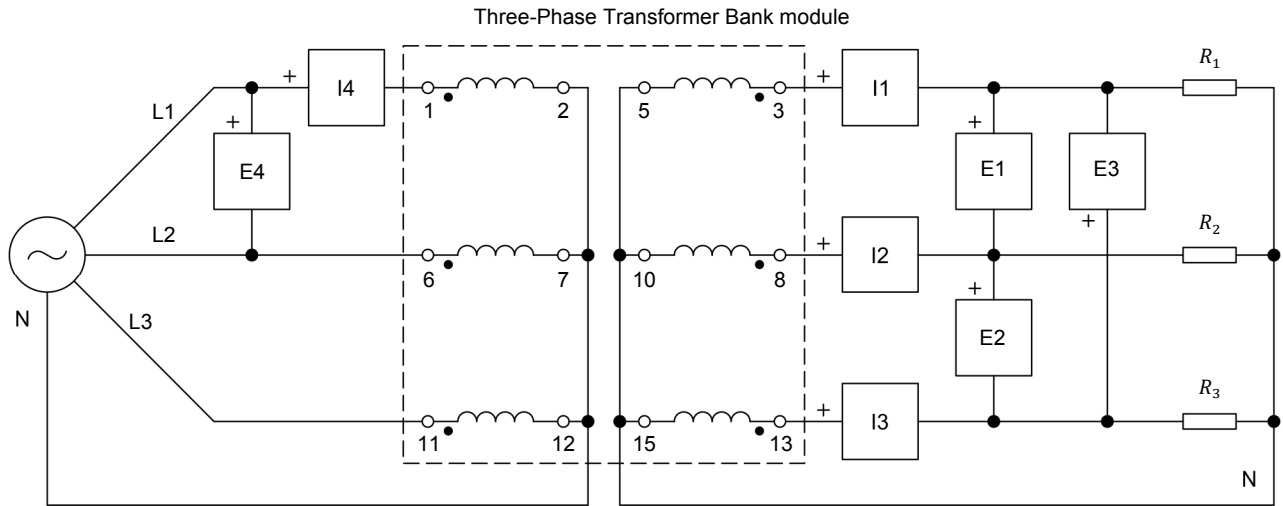

Local ac power network		R_1, R_2, R_3 (Ω)
Voltage (V)	Frequency (Hz)	
120	60	171
220/230	50/60	629
240	50	686
220	60	629

Figure 4. Three-phase transformer bank connected in a wye-wye configuration.

6. Make the necessary switch settings on the Resistive Load module in order to obtain the resistance value required.



The values of the resistive loads used in the circuits of this manual depend on the local ac power network voltage and frequency. Whenever necessary, a table below the circuit diagram indicates the value of each component for ac power network voltages of 120 V, 220 V, 230 V and 240 V, and for ac power network frequencies of 50 Hz and 60 Hz. Make sure to use the component values corresponding to the local ac power network voltage and frequency.



Appendix C lists the switch settings required on the Resistive Load module in order to obtain various resistance values.

- In the **Metering** window, make the required settings in order to measure the rms values (ac) of the line voltages $E_{Sec.1}$, $E_{Sec.2}$, and $E_{Sec.3}$ (inputs **E1**, **E2**, and **E3**, respectively), and the line currents $I_{Sec.1}$, $I_{Sec.2}$, and $I_{Sec.3}$ (inputs **I1**, **I2**, and **I3**, respectively) at the secondary of the three-phase transformer bank. Set two other meters to measure the line voltage $E_{Pri.}$ and current $I_{Pri.}$ at the primary of the three-phase transformer bank (inputs **E4** and **I4**, respectively).

Voltage, current, and phase relationships in a wye-wye configuration

In this section, you will measure the line voltages and currents at the secondary of the three-phase transformer bank, as well as a line voltage and current at the primary. Using the measured values, you will determine the voltage and current relationships between the primary and secondary windings of the three-phase transformer bank. You will then open the Phasor Analyzer and the Oscilloscope, and use both instruments to determine the phase shift between the line voltages at the secondary and the line voltages at the primary. Finally, you will confirm that the voltage, current, and phase relationships measured when the three-phase transformer bank is connected in a wye-wye configuration are coherent with the theory presented in the exercise discussion.

- On the **Power Supply** module, turn the three-phase ac power source on.
- In the **Metering** window, measure the line currents $I_{Sec.1}$, $I_{Sec.2}$, and $I_{Sec.3}$ at the secondary of the three-phase transformer bank, as well as the line current $I_{Pri.}$ at the primary. Record all values below.

$$I_{Sec.1} = \text{_____ A}$$

$$I_{Sec.2} = \text{_____ A}$$

$$I_{Sec.3} = \text{_____ A}$$

$$I_{Pri.} = \text{_____ A}$$

Make the necessary switch settings on the **Resistive Load** module so that the resistance value of the resistive load is infinite. Also, measure the line voltages $E_{Sec.1}$, $E_{Sec.2}$, and $E_{Sec.3}$ at the secondary of the three-phase transformer bank, as well as the line voltage $E_{Pri.}$ at the primary. Record all values below.

$$E_{Sec.1} = \text{_____ V}$$

$$E_{Sec.2} = \text{_____ V}$$

$$E_{Sec.3} = \text{_____ V}$$

$$E_{Pri.} = \text{_____ V}$$

10. Using the line voltage and current values you measured in the previous step, determine the voltage and current relationships between the primary windings and the secondary windings of the three-phase transformer bank when it is connected in a wye-wye configuration.

Voltage relationship ($E_{Pri.}:E_{Sec.}$) = ____: ____

Current relationship ($I_{Pri.}:I_{Sec.}$) = ____: ____

11. In LVDAC-EMS, open the **Phasor Analyzer** and make the required settings to observe the phasors of the line voltages $E_{Sec.1}$, $E_{Sec.2}$, and $E_{Sec.3}$ at the secondary (inputs **E1**, **E2**, and **E3**, respectively), as well as the line voltage $E_{Pri.}$ at the primary of the three-phase transformer bank (input **E4**). Set the phasor of the line voltage $E_{Pri.}$ (input **E4**) at the primary as the reference phasor.

Using the **Phasor Analyzer**, determine the phase shift between the line voltage $E_{Sec.1}$ at the secondary and the line voltage $E_{Pri.}$ at the primary of the three-phase transformer bank.

Phase shift between $E_{Sec.1}$ and $E_{Pri.}$ = _____°

12. In LVDAC-EMS, open the **Oscilloscope** and make the required settings to observe the waveforms of the line voltages $E_{Sec.1}$, $E_{Sec.2}$, and $E_{Sec.3}$ at the secondary (inputs **E1**, **E2**, and **E3**, respectively), as well as the line voltage $E_{Pri.}$ at the primary of the three-phase transformer bank (input **E4**).

Using the **Oscilloscope**, determine the phase shift between the line voltage $E_{Sec.1}$ at the secondary and the line voltage $E_{Pri.}$ at the primary of the three-phase transformer bank.

Phase shift between $E_{Sec.1}$ and $E_{Pri.}$ = _____°

Does the phase shift between the line voltage $E_{Sec.1}$ at the secondary and the line voltage $E_{Pri.}$ at the primary you just determined confirm the phase shift you obtained previously using the **Phasor Analyzer**?

Yes No

13. Are the voltage, current, and phase relationships you determined for the three-phase transformer bank connected in a wye-wye configuration coherent with the theory presented in the exercise discussion?

Yes No

14. On the **Power Supply** module, turn the three-phase ac power source off.

Voltage, current, and phase relationships in a wye-delta configuration

In this section, you will connect the three-phase transformer bank in a wye-delta configuration. You will measure the line voltages and currents at the secondary of the three-phase transformer bank, as well as a line voltage and current at the primary. Using the measured values, you will determine the voltage and current relationships between the primary and secondary windings of the three-phase transformer bank. You will then use the Phasor Analyzer and the Oscilloscope to determine the phase shift between the line voltages at the secondary and the line voltages at the primary. Finally, you will confirm that the voltage, current, and phase relationships measured when the three-phase transformer bank is connected in a wye-delta configuration are coherent with the theory presented in the exercise discussion.

- Connect the equipment as shown in Figure 5. In this circuit, only the connections at the secondary windings of the three-phase transformer bank have been modified with respect to the circuit used in the previous section.

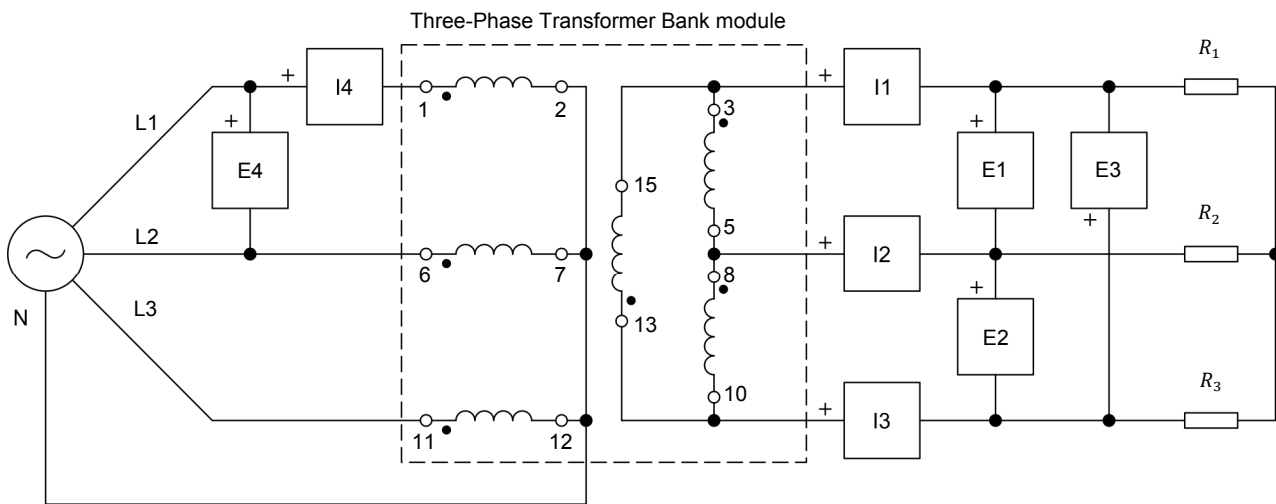

Local ac power network		R_1, R_2, R_3 (Ω)
Voltage (V)	Frequency (Hz)	
120	60	171
220/230	50/60	629
240	50	686
220	60	629

Figure 5. Three-phase transformer bank connected in a wye-delta configuration.

- On the Power Supply module, turn the three-phase ac power source on.

17. In the **Metering** window, measure the line currents $I_{Sec.1}$, $I_{Sec.2}$, and $I_{Sec.3}$ at the secondary of the three-phase transformer bank, as well as the line current $I_{Pri.}$ at the primary. Record all values below.

$$I_{Sec.1} = \text{_____ A}$$

$$I_{Sec.2} = \text{_____ A}$$

$$I_{Sec.3} = \text{_____ A}$$

$$I_{Pri.} = \text{_____ A}$$

Make the necessary switch settings on the **Resistive Load** module so that the resistance value of the resistive load is infinite. Also, measure the line voltages $E_{Sec.1}$, $E_{Sec.2}$, and $E_{Sec.3}$ at the secondary of the three-phase transformer bank, as well as the line voltage $E_{Pri.}$ at the primary. Record all values below.

$$E_{Sec.1} = \text{_____ V}$$

$$E_{Sec.2} = \text{_____ V}$$

$$E_{Sec.3} = \text{_____ V}$$

$$E_{Pri.} = \text{_____ V}$$

18. Using the line voltage and current values you measured in the previous step, determine the voltage and current relationships between the primary and the secondary windings of the three-phase transformer bank when it is connected in a wye-delta configuration.

$$\text{Voltage relationship } (E_{Pri.}:E_{Sec.}) = \text{____:____}$$

$$\text{Current r relationship } (I_{Pri.}:I_{Sec.}) = \text{____:____}$$

19. Using the **Phasor Analyzer** and the **Oscilloscope**, determine the phase shift between the line voltage $E_{Sec.1}$ at the secondary and the line voltage $E_{Pri.}$ at the primary of the three-phase transformer bank.

$$\text{Phase shift between } E_{Sec.1} \text{ and } E_{Pri.} = \text{_____}^\circ$$

20. Are the voltage, current, and phase relationships you determined for the three-phase transformer bank connected in a wye-delta configuration coherent with the theory presented in the exercise discussion?

Yes No

21. On the **Power Supply** module, turn the three-phase ac power source off.

Voltage, current, and phase relationships in a delta-delta configuration

In this section, you will connect the three-phase transformer bank in a delta-delta configuration. You will measure the line voltages and currents at the secondary of the three-phase transformer bank, as well as a line voltage and current at the primary. Using the measured values, you will determine the voltage and current relationships between the primary and secondary windings of the three-phase transformer bank. You will then use the Phasor Analyzer and the Oscilloscope to determine the phase shift between the line voltages at the secondary and the line voltages at the primary. You will confirm that the voltage, current, and phase relationships measured when the three-phase transformer bank is connected in a delta-delta configuration are coherent with the theory presented in the exercise discussion. You will then reverse the connection of the windings at the secondary of the three-phase transformer bank. You will observe the resulting phase shift between the secondary and the primary line voltages using the Phasor Analyzer and the Oscilloscope, and analyze the results.

- 22.** Connect the equipment as shown in Figure 6. In this circuit, only the connections at the primary windings of the three-phase transformer bank have been modified with respect to the circuit used in the previous section.

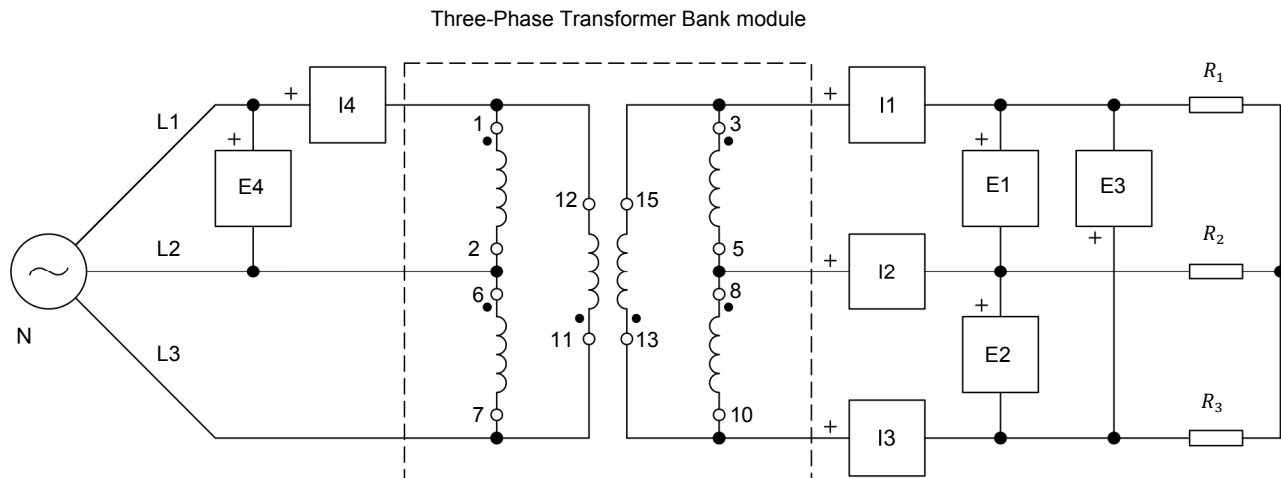

Local ac power network		R_1, R_2, R_3 (Ω)
Voltage (V)	Frequency (Hz)	
120	60	171
220/230	50/60	629
240	50	686
220	60	629

Figure 6. Three-phase transformer bank connected in a delta-delta configuration.

- 23.** On the [Power Supply](#) module, turn the three-phase ac power source on.

24. In the **Metering** window, measure the line currents $I_{Sec.1}$, $I_{Sec.2}$, and $I_{Sec.3}$ at the secondary of the three-phase transformer bank, as well as the line current $I_{Pri.}$ at the primary. Record all values below.

$$I_{Sec.1} = \text{_____ A}$$

$$I_{Sec.2} = \text{_____ A}$$

$$I_{Sec.3} = \text{_____ A}$$

$$I_{Pri.} = \text{_____ A}$$

Make the necessary switch settings on the **Resistive Load** module so that the resistance value of the resistive load is infinite. Also, measure the line voltages $E_{Sec.1}$, $E_{Sec.2}$, and $E_{Sec.3}$ at the secondary of the three-phase transformer bank, as well as the line voltage $E_{Pri.}$ at the primary. Record all values below.

$$E_{Sec.1} = \text{_____ V}$$

$$E_{Sec.2} = \text{_____ V}$$

$$E_{Sec.3} = \text{_____ V}$$

$$E_{Pri.} = \text{_____ V}$$

25. Using the line voltage and current values you measured in the previous step, determine the voltage and current relationships between the primary and the secondary of the three-phase transformer bank when it is connected in a delta-delta configuration.

$$\text{Voltage relationship } (E_{Pri.}:E_{Sec.}) = \text{____:____}$$

$$\text{Current relationship } (I_{Pri.}:I_{Sec.}) = \text{____:____}$$

26. Using the **Phasor Analyzer** and the **Oscilloscope**, determine the phase shift between the line voltage $E_{Sec.1}$ at the secondary and the line voltage $E_{Pri.}$ at the primary of the three-phase transformer bank.

$$\text{Phase shift between } E_{Sec.1} \text{ and } E_{Pri.} = \text{_____}^\circ$$

27. Are the voltage, current, and phase relationships you determined for the three-phase transformer bank connected in a delta-delta configuration coherent with the theory presented in the exercise discussion?

Yes No

28. On the **Power Supply** module, turn the three-phase ac power source off.

29. Reverse the connections at each of the secondary windings of the three-phase transformer bank. The circuit should now be as shown in Figure 7.

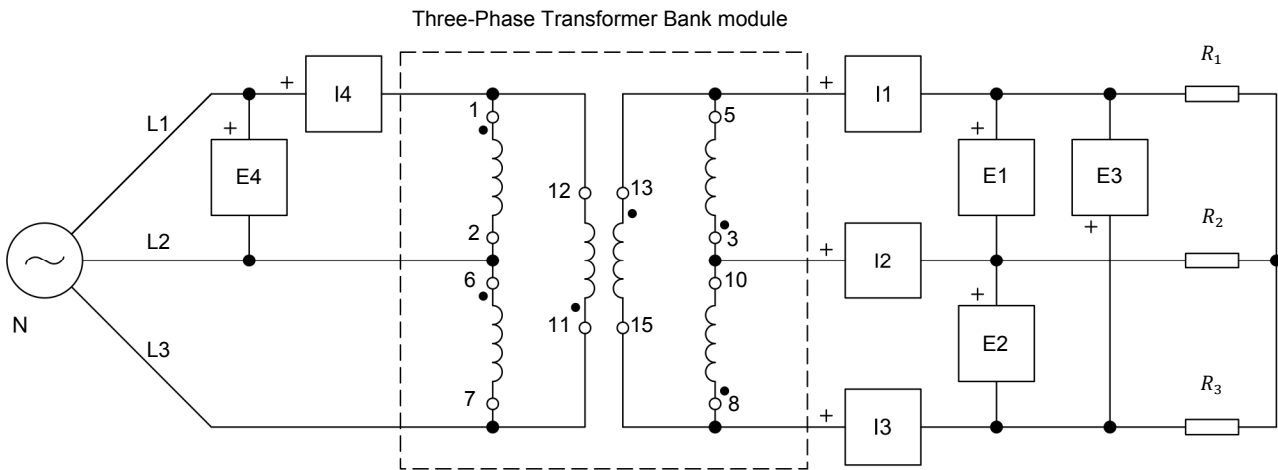

Local ac power network		R_1, R_2, R_3 (Ω)
Voltage (V)	Frequency (Hz)	
120	60	171
220/230	50/60	629
240	50	686
220	60	629

Figure 7. Three-phase transformer bank connected in a delta-delta configuration with reversed connections at the secondary windings.

30. On the Power Supply module, turn the three-phase ac power source on.
31. Using the Phasor Analyzer and the Oscilloscope, determine the phase shift between the line voltage $E_{Sec.1}$ at the secondary and the line voltage $E_{Pri.}$ at the primary of the three-phase transformer bank.

Phase shift between $E_{Sec.1}$ and $E_{Pri.}$ = _____°

32. What happens to the phase shift between the line voltage $E_{Sec.1}$ at the secondary and the line voltage $E_{Pri.}$ at the primary when the connections at the secondary windings of the three-phase transformer bank are reversed?

Do your results confirm that it is important to respect the winding polarity when connecting the windings of a three-phase transformer bank? Briefly explain why.

- 33.** On the [Power Supply](#) module, turn the three-phase ac power source off.

Voltage, current, and phase relationships in a delta-wye configuration

In this section, you will connect the three-phase transformer bank in a delta-wye configuration. You will measure the line voltages and currents at the secondary of the three-phase transformer bank, as well as a line voltage and current at the primary. Using the measured values, you will determine the voltage and current relationships between the primary and secondary windings of the three-phase transformer bank. You will then use the Phasor Analyzer and the Oscilloscope to determine the phase shift between the line voltages at the secondary and the line voltages at the primary. Finally, you will confirm that the voltage, current, and phase relationships measured when the three-phase transformer bank is connected in a delta-wye configuration are coherent with the theory presented in the exercise discussion. You will then reverse the connections of the windings at the secondary of the three-phase transformer bank. You will observe the resulting phase shift between the secondary and the primary line voltages using the Phasor Analyzer and the Oscilloscope, and analyze the results.

- 34.** Connect the equipment as shown in Figure 8. In this circuit, only the connections at the secondary windings of the three-phase transformer bank have been modified with respect to the last circuit used in the previous section. Make sure that the numbers of the secondary terminals you use on the [Three-Phase Transformer Bank](#) correspond to the numbers of secondary winding taps SWT1, SWT2, and SWT3 indicated in the table of Figure 8.



If you perform the exercises with local ac power networks having a voltage of 220 V, 230 V and 240 V, the connections at the secondary windings of the [Three-Phase Transformer Bank](#) cause the voltage at the secondary to be equal to the voltage at the primary divided by $\sqrt{3}$ (i.e., the three-phase transformer bank voltage ratio is equal to $\sqrt{3}:1$). This is done in order to lower the voltage measured at the secondary of the three-phase transformer bank, which would otherwise reach too high values for these local ac power network voltages.

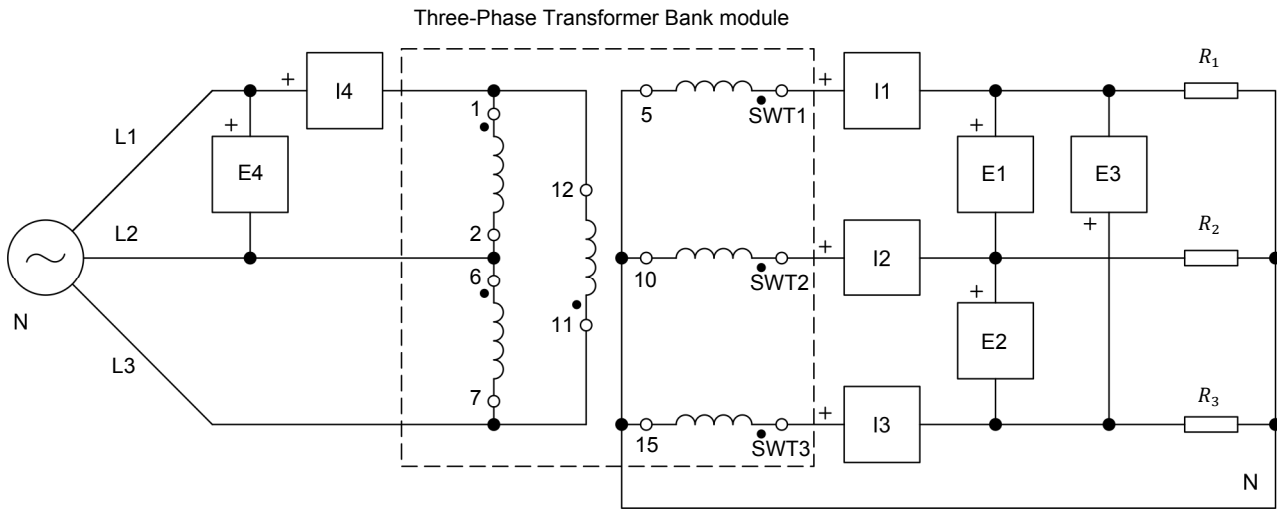

Local ac power network		SWT1	SWT2	SWT3	R_1, R_2, R_3 (Ω)
Voltage (V)	Frequency (Hz)				
120	60	3	8	13	300
220/230	50/60	4	9	14	629
240	50	4	9	14	686
220	60	4	9	14	629

Figure 8. Three-phase transformer bank connected in a delta-wye configuration.

35. Make the necessary switch settings on the **Resistive Load** module in order to obtain the resistance value required.
36. On the **Power Supply** module, turn the three-phase ac power source on.

CAUTION

The voltage and power ratings of the **Resistive Load** module are significantly exceeded in this manipulation. It is therefore important that you perform the remainder of this step in less than 2 minutes to avoid damaging the **Resistive Load** module.

In the **Metering** window, measure the line currents $I_{Sec.1}$, $I_{Sec.2}$, and $I_{Sec.3}$ at the secondary of the three-phase transformer bank, as well as the line current $I_{Pri.}$ at the primary. Record all values below.

$$I_{Sec.1} = \text{_____ A}$$

$$I_{Sec.2} = \text{_____ A}$$

$$I_{Sec.3} = \text{_____ A}$$

$$I_{Pri.} = \text{_____ A}$$

Make the necessary switch settings on the **Resistive Load** module so that the resistance value of the resistive load is infinite. Also, measure the line voltages $E_{Sec.1}$, $E_{Sec.2}$, and $E_{Sec.3}$ at the secondary of the three-phase transformer bank, as well as the line voltage $E_{Pri.}$ at the primary. Record all values below.

$$E_{Sec.1} = \text{_____ V}$$

$$E_{Sec.2} = \text{_____ V}$$

$$E_{Sec.3} = \text{_____ V}$$

$$E_{Pri.} = \text{_____ V}$$

On the **Power Supply** module, turn the three-phase ac power source off.

- 37.** Using the line voltage and current values you recorded in the previous step, determine the voltage and current relationships between the primary and the secondary of the three-phase transformer bank connected in a delta-wye configuration.

Voltage relationship ($E_{Pri.}:E_{Sec.}$) = ____: ____

Current relationship ($I_{Pri.}:I_{Sec.}$) = ____: ____



If you perform the exercises with local ac power networks having a voltage of 220 V, 230 V and 240 V, be sure to determine the voltage and current relationships between the primary and the secondary of the three-phase transformer bank that are due exclusively to its delta-wye configuration (i.e., do not take into account the $\sqrt{3}:1$ voltage ratio introduced by the fact that you connected the three-phase transformer bank as a step-down transformer). To do so, multiply the secondary voltage values you obtained in the previous step by $\sqrt{3}$ and divide the secondary current values you obtained in the previous step by $\sqrt{3}$.

38. On the **Power Supply** module, turn the three-phase ac power source on.

CAUTION

The voltage and power ratings of the **Resistive Load** module are significantly exceeded in this manipulation. It is therefore important that you perform the remainder of this step in less than 2 minutes to avoid damaging the **Resistive Load** module.

Using the **Phasor Analyzer** and the **Oscilloscope**, determine the phase shift between the line voltage $E_{Sec.1}$ at the secondary and the line voltage $E_{Pri.}$ at the primary of the three-phase transformer bank.

Phase shift between $E_{Sec.1}$ and $E_{Pri.}$ = _____°

On the **Power Supply** module, turn the three-phase ac power source off.

39. Are the voltage, current, and phase relationships you determined for the three-phase transformer bank connected in a delta-wye configuration coherent with the theory presented in the exercise discussion?

Yes No

40. Reverse the connections at each of the secondary windings of the three-phase transformer bank. The circuit should now be as shown in Figure 9.

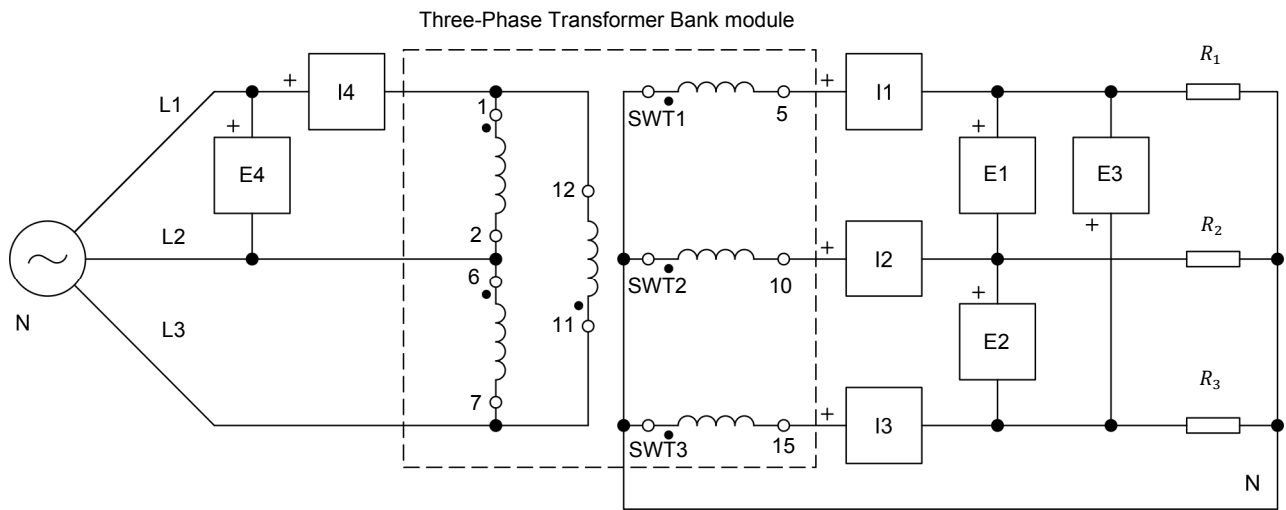

Local ac power network		SWT1	SWT2	SWT3	R_1, R_2, R_3 (Ω)
Voltage (V)	Frequency (Hz)				
120	60	3	8	13	300
220/230	50/60	4	9	14	629
240	50	4	9	14	686
220	60	4	9	14	629

Figure 9. Three-phase transformer bank connected in a delta-wye configuration with reversed connections at the secondary windings.

41. On the Power Supply module, turn the three-phase ac power source on.

CAUTION

The voltage and power ratings of the Resistive Load module are significantly exceeded in this manipulation. It is therefore important that you perform the remainder of this step in less than 2 minutes to avoid damaging the Resistive Load module.

Using the Phasor Analyzer and the Oscilloscope, determine the phase shift between the line voltage $E_{Sec.1}$ at the secondary and the line voltage $E_{Pri.}$ at the primary of the three-phase transformer bank.

Phase shift between $E_{Sec.1}$ and $E_{Pri.}$ = _____ °

On the Power Supply module, turn the three-phase ac power source off.

42. What happens to the phase shift between the line voltage $E_{Sec.1}$ at the secondary and the line voltage $E_{Pri.}$ at the primary when the connections at the secondary windings of the three-phase transformer bank are reversed?

Is the effect of reversing the connections at the secondary windings of the three-phase transformer bank connected in a delta-wye configuration similar to what you observed in step 31 when the three-phase transformer bank is connected in a delta-delta configuration?

- Yes No

43. Close **LVDAC-EMS**, then turn off all the equipment. Disconnect all leads and return them to their storage location.

CONCLUSION

In this exercise, you learned how to connect three-phase transformer banks in wye-wye, delta-delta, wye-delta, and delta-wye configurations. You also determined the voltage, current, and phase relationships between the primary windings and the secondary windings of a three-phase transformer bank for each of these configurations. You saw the uses of three-phase transformer banks in three-phase ac power circuits.

REVIEW QUESTIONS

1. What are the main differences between single-unit, three-phase power transformers and three-phase transformer banks?

2. How is it possible to confirm that the wye-connected secondary windings of a three-phase transformer bank are properly connected (i.e., that winding polarity is respected)? Explain briefly.

3. How is it possible to confirm that the delta-connected secondary windings of a three-phase transformer bank are properly connected (i.e., that winding polarity is respected) before closing the delta? Explain briefly.

4. Consider a three-phase transformer bank connected in a delta-wye configuration. Each winding at the primary of the three-phase transformer bank is made of 800 turns of wire, while each winding at the secondary is made of 1340 turns of wire. Knowing that the line voltage $E_{Pri.}$ at the primary is equal to 208 V, determine the line voltage $E_{Sec.}$ at the secondary.

5. Consider a three-phase transformer bank connected in a wye-delta configuration. Each winding at the primary of the three-phase transformer bank is made of 4800 turns of wire, while each winding at the secondary is made of 1600 turns of wire. Knowing that the line voltage $E_{Pri.}$ at the primary is equal to 75 kV, determine the line voltage $E_{Sec.}$ at the secondary.

Equipment Utilization Chart

The following equipment is required to perform the exercises in this manual.

Equipment		Exercise 1
Model	Description	
8131 ⁽¹⁾	Workstation	1
8311-0 ⁽²⁾	Resistive Load	1
8348-4	Three-Phase Transformer Bank	1
8951-L	Connection Leads	1
8823	Power Supply	1
8990	Host Computer	1
9063-B ⁽³⁾	Data Acquisition and Control Interface	1
30004-2	24 V AC Power Supply	1
<p>(1) The Mobile Workstation, Model 8110, and the Workstation, Model 8134, can also be used.</p> <p>(2) Resistive Load unit with voltage rating corresponding to your local ac power network voltage (Model variant 8311-0).</p> <p>(3) Model 9063-B consists of the Data Acquisition and Control Interface, Model 9063, with the Computer-Based Instrumentation function set, Model 9069-1.</p>		

Glossary of New Terms

**single-unit,
three-phase power
transformer**

Single-unit three-phase power transformers are constructed by winding three single-phase power transformers around a single core. For a given power rating, single-unit three-phase power transformers are smaller, require less material, and are less costly than three-phase transformer banks. However, single-unit three-phase power transformers are more difficult to maintain than three-phase transformer banks because, when one of the windings is defective, the whole unit must be replaced instead of replacing the defective transformer in a bank.

**three-phase
transformer bank**

Three-phase transformer banks consist of three individual single-phase power transformers that are grouped together. For a given power rating, three-phase transformer banks are bulkier, require more material, and are more costly than single-unit three-phase power transformers. However, three-phase transformer banks, are easier to maintain than single-unit three-phase power transformers because, when one of the windings is defective, only one of the transformers in the bank has to be replaced instead of the whole unit.

**three-phase
transformer
configuration**

The three-phase transformer configuration of a three-phase power transformer determines how the primary and secondary windings are connected. The four most common types of three-phase transformer configurations are wye-wye, delta-delta, wye-delta, and delta-wye. Each of these configurations presents different characteristics. When connecting a three-phase power transformer in a circuit, it is therefore important to determine which characteristics are advantageous to the circuit, and to choose the appropriate three-phase transformer configuration accordingly.

Impedance Table for the Load Modules

The following table gives impedance values which can be obtained using either the Resistive Load, Model 8311, the Inductive Load, Model 8321, or the Capacitive Load, Model 8331. Figure 10 shows the load elements and connections. Other parallel combinations can be used to obtain the same impedance values listed.

Table 2. Impedance table for the load modules.

Impedance (Ω)			Position of the switches								
120 V 60 Hz	220/230 V 50 Hz/60 Hz	240 V 50 Hz	1	2	3	4	5	6	7	8	9
1200	4400	4800									
600	2200	2400									
300	1100	1200									
400	1467	1600									
240	880	960									
200	733	800									
171	629	686									
150	550	600									
133	489	533									
120	440	480									
109	400	436									
100	367	400									
92	338	369									
86	314	343									
80	293	320									
75	275	300									
71	259	282									
67	244	267									
63	232	253									
60	220	240									
57	210	229									

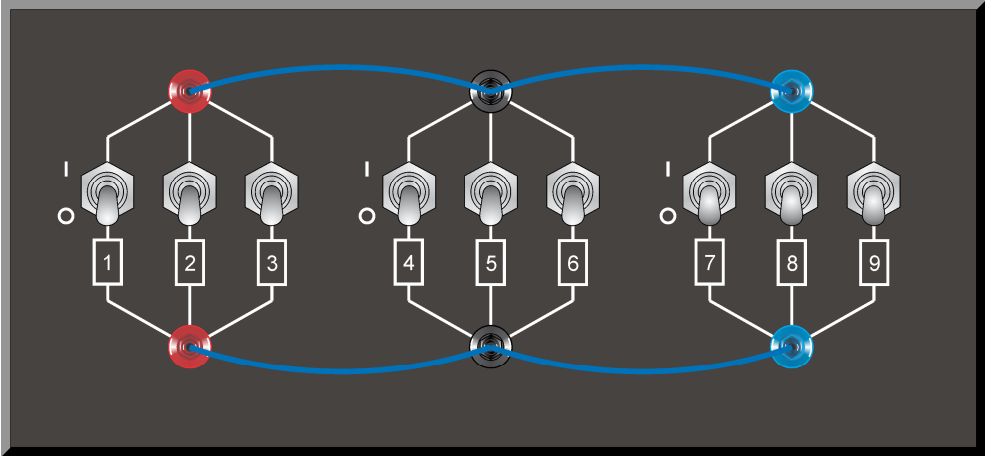
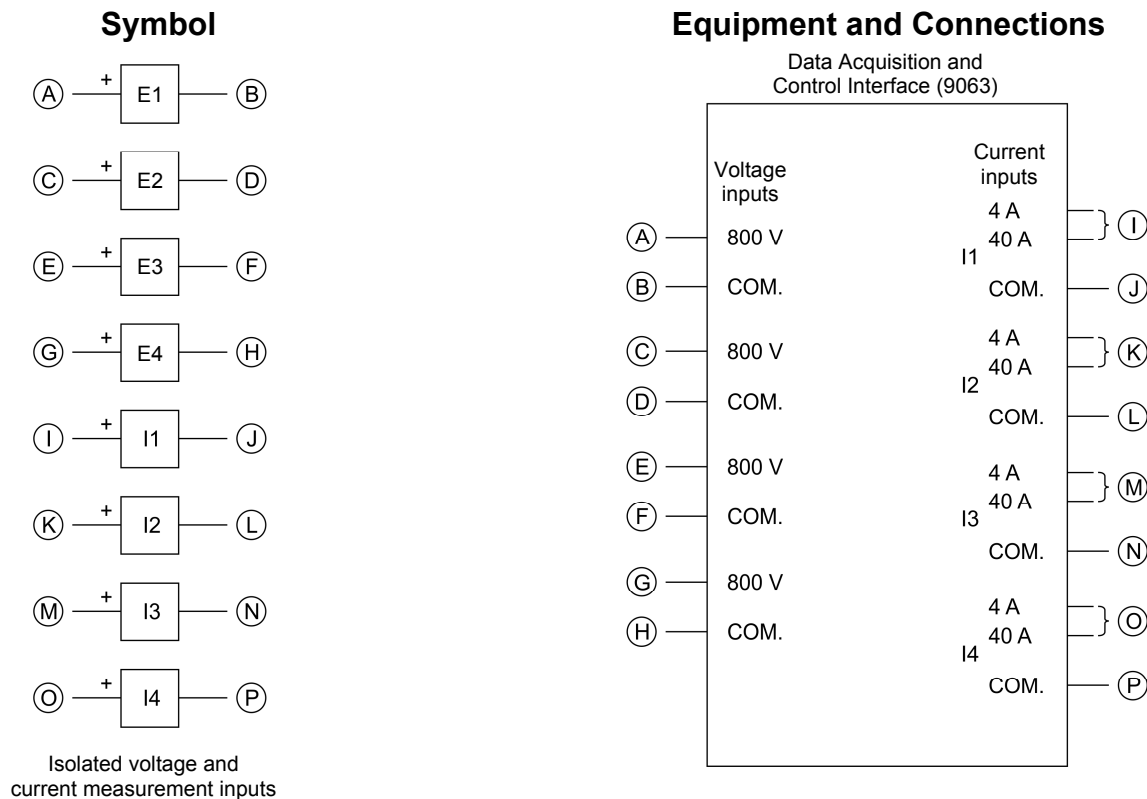

Figure 10. Location of the load elements on the Resistive Load, Inductive Load, and Capacitive Load, Models 8311, 8321, and 8331, respectively.

Circuit Diagram Symbols

Various symbols are used in the circuit diagrams of this manual. Each symbol is a functional representation of a particular electrical device that can be implemented using the equipment. The use of these symbols greatly simplifies the number of interconnections that need to be shown on the circuit diagram, and thus, makes it easier to understand the circuit operation.

For each symbol other than those of power sources, resistors, inductors, and capacitors, this appendix gives the name of the device which the symbol represents, as well as the equipment and the connections required to properly connect the device to a circuit. Notice that the terminals of each symbol are identified using circled letters. The same circled letters identify the corresponding terminals in the Equipment and Connections diagram. Also notice that the numbers (when present) in the Equipment and Connections diagrams correspond to terminal numbering used on the actual equipment.



When a current at inputs I1, I2, I3, or I4 exceeds 4 A (either permanently or momentarily), use the corresponding 40 A input terminal and set the Range parameter of the corresponding input to High in the Data Acquisition and Control Settings window of LVDAC-EMS.

Symbol

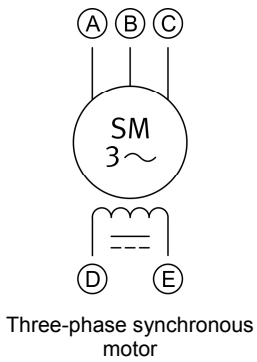
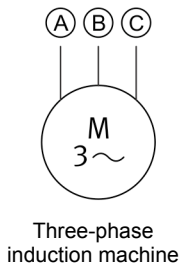
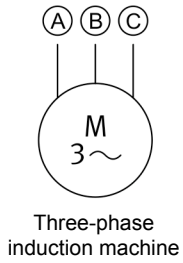

Equipment and Connections

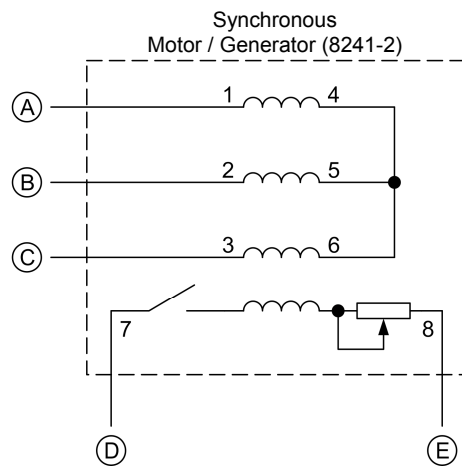
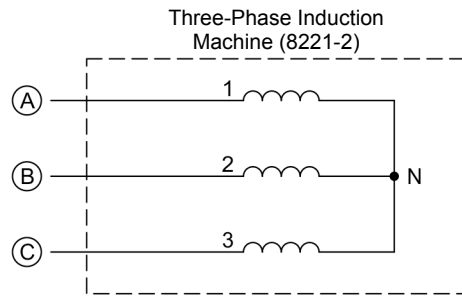
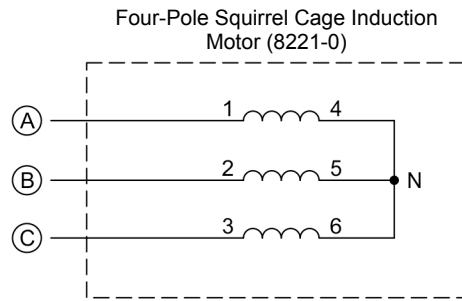

Symbol

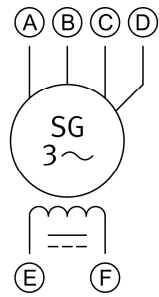

Three-phase synchronous generator

Equipment and Connections

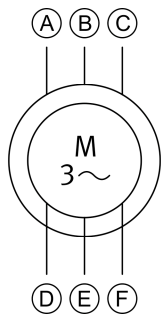
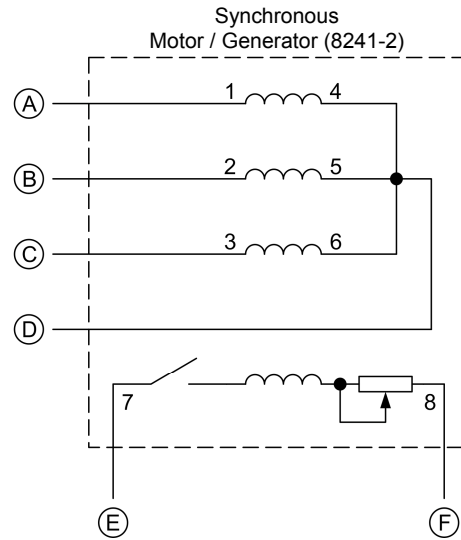

Three-phase wound-rotor induction machine

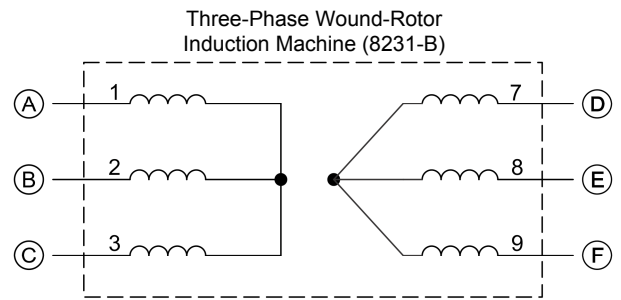

Symbol

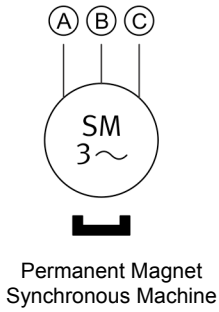

Equipment and Connections

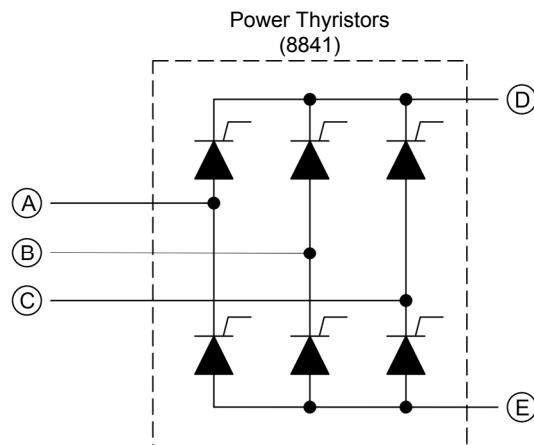
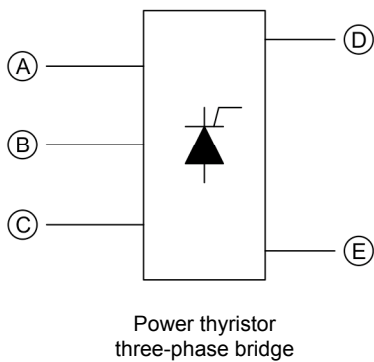
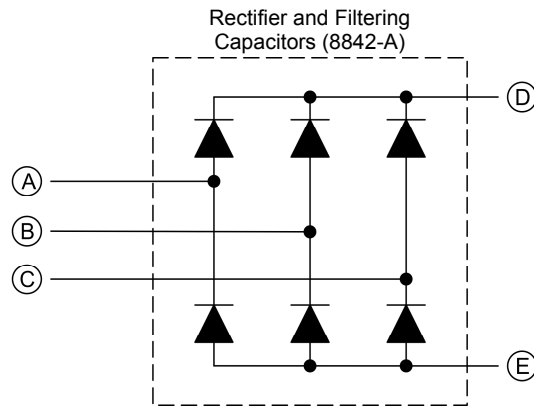
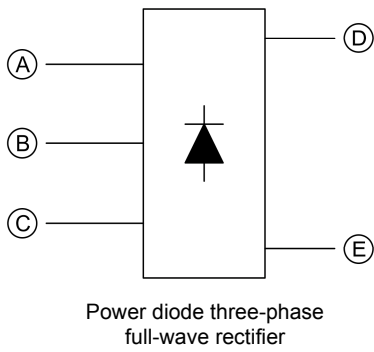
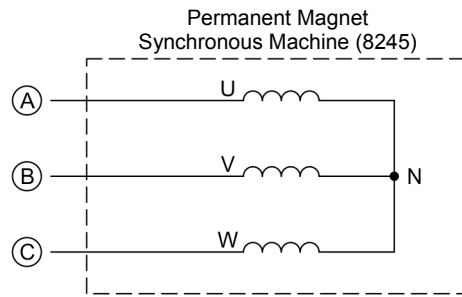

Symbol

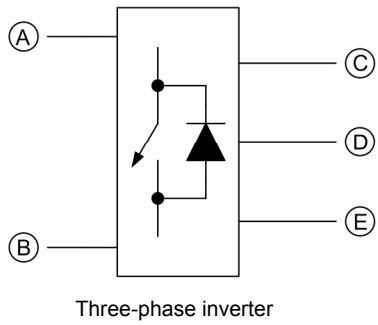

Equipment and Connections

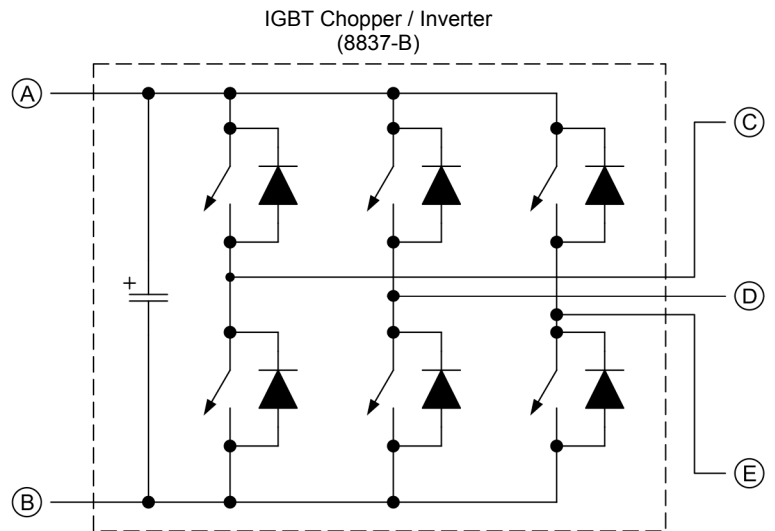

The electronic switch symbol in the three-phase inverter above replaces MOSFET or IGBT symbols. It is not an IEC or ANSI symbol.

Index of New Terms



The bold page number indicates the main entry. Refer to the Glossary of New Terms above for definitions of new terms.

single-unit, three-phase power transformers	2
three-phase transformer banks	2 , 3, 5, 9
three-phase transformer configurations	5 , 8, 9

Bibliography

Boylestad, Robert L., *Introductory Circuit Analysis*, 11th Edition, Upper Saddle River, Prentice Hall, 2006, ISBN 978-0131730441.

Wildi, Theodore, *Electrical Machines, Drives, and Power Systems*, 6th Edition, Upper Saddle River, Prentice Hall, 2005, ISBN 978-0131776913.